

LUG TYPE (SDV-3, SDV-3R)

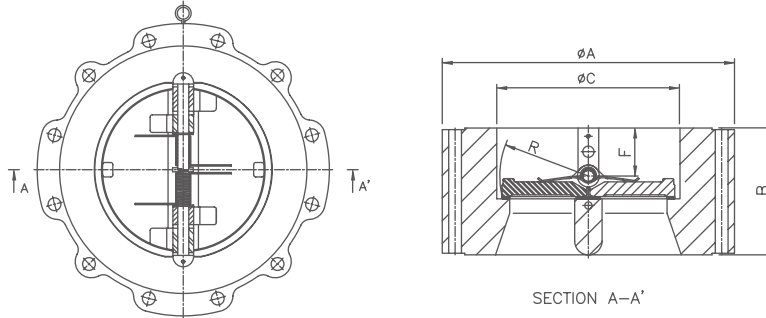

Size mm(inch)	Pressure Rating (KS, ANSI)	Type Facing	Dimensions(mm)					Flange Bolt Circle(mm)	No. of Bolts	Bolt Dia.	Bolt Length(mm)		Weight (kg)
			ØA	B	ØC	F	R				FF - RF	RTJ	
50 (2)	150	RF.R-22	152	60	60	33	27	120.6	4	5/8	160	170	7
	300	RF.R-23	165	60	60	33	27	127	8	5/8	165	185	8
	600	RF.R-23	165	60	60	33	27	127	8	5/8	185	190	8
	900	RF.R-24	216	70	57	33	27	165.1	8	7/8	240	245	16
	1500	RF.R-24	216	70	57	33	27	165.1	8	7/8	240	245	16
	2500	RF.R-26	235	70	57	33	27	171.4	8	1	280	280	29
80 (3)	150	RF.R-29	190	73	89	36	41	152.4	4	5/8	180	190	12
	300	RF.R-31	210	73	89	36	41	168.1	8	3/4	200	215	14
	600	RF.R-31	210	73	89	36	41	168.1	8	3/4	220	225	14
	900	RF.R-31	241	83	89	34	42	190.5	8	7/8	255	260	25
	1500	RF.R-35	267	83	89	34	42	203.2	8	1 1/8	285	295	29
	2500	RF.R-32	305	86	89	36	42	228.6	8	1 1/4	335	345	40
100 (4)	150	RF.R-36	229	73	114	38	54	190.5	8	5/8	180	190	19
	300	RF.R-37	254	73	114	38	55	200.2	8	3/4	205	225	23
	600	RF.R-37	273	79	114	42	55	215.9	8	7/8	250	255	30
	900	RF.R-37	292	102	114	40	55	235	8	1 1/8	300	305	45
	1500	RF.R-39	311	102	114	40	55	241.3	8	1 1/4	325	335	51
	2500	RF.R-38	356	105	114	34	55	273	8	1 1/2	395	400	82
150 (6)	150	RF.R-43	279	98	168	44	79	241.3	8	3/4	215	230	32
	300	RF.R-43	318	98	168	44	79	269.7	12	3/4	240	255	45
	600	RF.R-45	356	136	168	46	82	292.1	12	1	335	340	81
	900	RF.R-45	381	159	168	56	82	317.5	12	1 1/8	380	385	115
	1500	RF.R-46	394	159	168	56	82	317.5	12	1 1/8	445	460	118
	2500	RF.R-47	483	159	168	56	82	368.3	8	2	535	550	197
200 (8)	150	RF.R-48	343	127	219	48	102	298.4	8	3/4	250	265	63
	300	RF.R-49	381	127	219	48	102	330.2	12	7/8	290	305	78
	600	RF.R-49	419	165	219	54	105	349.2	12	1 1/8	385	390	134
	900	RF.R-49	470	206	219	73	105	393.7	12	1 1/8	455	465	217
	1500	RF.R-50	483	206	210	73	105	393.7	12	1 1/8	530	545	283
	2500	RF.R-51	552	206	210	73	105	438.2	12	2	620	645	300
250 (10)	150	RF.R-52	406	146	274	56	126	362	12	7/8	285	300	93
	300	RF.R-53	444	146	274	52	126	387.4	16	1	330	345	115
	600	RF.R-53	508	213	274	70	133	431.8	16	1 1/4	455	465	234
	900	RF.R-53	546	241	274	87	133	469.9	16	1 1/8	505	510	330
	1500	RF.R-54	584	248	265	87	133	482.6	12	1 1/8	615	630	361
	2500	RF.R-55	673	254	265	87	133	539.8	12	2 1/2	770	610	512
300 (12)	150	RF.R-56	483	181	324	70	152	431.8	12	7/8	325	335	170
	300	RF.R-57	521	181	324	70	152	450.8	16	1 1/8	380	395	242
	600	RF.R-57	559	229	324	67	152	489	20	1 1/4	480	485	304
	900	RF.R-57	610	292	318	100	150	533.4	20	1 1/8	575	580	509
	1500	RF.R-58	673	305	318	102	150	571.5	16	2	710	735	637
	2500	RF.R-60	762	305	316	103	150	619.3	12	2 3/4	875	915	880
350 (14)	150	RF.R-59	533	184	356	90	170	476.2	12	1	340	355	200
	300	RF.R-61	584	222	356	94	170	514.4	20	1 1/8	425	440	310

LUG TYPE (SDV-3, SDV-3R)

Size mm(inch)	Pressure Rating (KS, ANSI)	Type Facing	Dimensions(mm)					Flange Bolt Circle(mm)	No.of Bolts	Bolt Dia.	Bolt Length(mm)		Weight (kg)
			ØA	B	ØC	F	R				FF - RF	RTJ	
350 (14)	600	RF.R-61	603	273	356	103	164	527	20	1½	535	540	430
	900	RF.R-62	641	356	350	130	168	558.8	20	1½	655	670	775
	1500	RF.R-63	749	356	350	130	168	635	16	2¼	795	825	896
400 (16)	150	RF.R-64	597	191	406	86	195	539.8	16	1	350	365	246
	300	RF.R-65	648	232	406	95	195	571.5	20	1¼	450	465	440
	600	RF.R-65	686	305	406	92	198	603.2	20	1½	585	595	620
	900	RF.R-66	705	384	406	137	198	616	20	1½	700	715	895
450 (18)	1500	RF.R-67	826	384	406	137	198	704.8	16	2½	865	900	1280
	150	RF.R-68	635	203	457	86	219	577.8	16	1½	375	390	290
	300	RF.R-69	711	264	457	127	219	628.6	24	1¼	490	505	558
	600	RF.R-69	743	362	457	121	228	654	20	1½	665	675	902
500 (20)	900	RF.R-70	787	451	457	167	232	685.8	20	1½	805	825	1188
	1500	RF.R-71	914	468	457	167	216	774.7	16	2¼	995	1035	1780
	150	RF.R-72	693	219	508	89	244	635	20	1½	400	410	348
	300	RF.R-73	775	292	508	108	244	685.8	24	1¼	520	545	766
600 (24)	600	RF.R-73	813	368	508	116	248	723.9	24	1½	685	695	1072
	900	RF.R-74	857	451	508	116	248	749.3	20	2	825	845	1496
	1500	RF.R-75	984	533	508	116	248	831.8	16	3	1105	1140	2235
	150	RF.R-76	813	222	610	86	292	749.3	20	1¼	420	430	510
650 (26")	300	RF.R-77	914	318	610	122	292	812.8	24	1½	575	600	1190
	600	RF.R-77	940	438	610	133	295	838.2	24	1½	795	610	1825
	900	RF.R-78	1041	495	610	149	300	901.7	20	2½	960	990	2351
	1500	RF.R-79	1168	559	610	149	300	990.6	16	3½	1205	1255	3250
700 (28")	150	RF	870	222	660	90	316	806.4	24	1¼	470	-	680
	300	RF.R-93	972	318	660	90	316	876.3	28	1½	610	635	1308
	600	RF.R-93	1016	457	660	122	312	914.4	28	1½	820	840	2227
	900	RF.R-100	1086	533	660	122	312	952.5	20	2¼	1005	1050	2860
750 (30")	150	RF	927	305	711	132	351	863.6	28	1¼	555	-	970
	300	RF.R-94	1035	368	711	132	351	939.8	28	1½	670	695	1670
	600	RF.R-94	1073	483	711	165	347	965.2	28	2	890	900	2480
	900	RF.R-101	1168	572	711	165	347	1022.4	20	3	1070	1105	3080
800 (32")	150	RF	984	305	762	137	371	914.4	28	1¼	560	-	1029
	300	RF.R-95	1092	368	762	137	375	997	28	1¼	685	710	1870
	600	RF.R-95	1130	505	762	165	362	1022.4	28	2	895	910	2880
	900	RF.R-102	1232	635	762	165	362	1085.8	20	3	1150	1185	3956
900 (36")	150	RF	1060	356	813	119	389	977.9	28	1½	635	-	1569
	300	RF.R-96	1149	368	813	119	389	1054.1	28	1½	710	740	2320
	600	RF.R-96	1194	533	813	145	370	1079.5	28	2¼	940	965	3238
	900	RF.R-103	1314	660	813	145	370	1155.7	20	3¼	1205	1240	4381
1000 (40")	150	RF	1168	368	914	143	452	1085.9	32	1½	665	-	1824
	300	RF.R-98	1270	483	914	165	452	1168.4	32	2	840	875	3351
	600	RF.R-98	1314	635	914	210	445	1193.8	28	2½	1010	1095	4870
	900	RF.R-105	1460	718	914	210	445	1289	20	3½	1300	1350	6434
1050 (42")	150	RF	1289	432	1016	499	499	1200.2	36	1½	730	-	2470
	300	RF	1238	546	1016	499	499	1155.7	32	1½	900	-	4290
	600	RF	1321	660	1016	492	492	1212.8	32	2¼	1150	-	5120
	900	RF	1511	762	1016	492	492	1339.8	24	3½	1395	-	8416
1200 (48")	150	RF	1346	432	1067	527	527	1257.3	36	1½	740	-	2820
	300	RF	1289	568	1067	522	522	1206.5	32	1½	930	-	4820
	600	RF	1403	702	1067	240	520	1282.7	28	2½	1225	-	6240
	900	RF	1562	787	1067	260	520	1390.6	24	3½	1440	-	-
1350 (54")	150	RF	1511	524	1219	178	603	1422.4	44	1½	855	-	4171
	300	RF	1467	629	1219	171	591	1371.6	32	1½	1035	-	6236
	600	RF	1594	787	1219	270	591	1460.5	32	2¼	1365	-	-
1500 (60")	150	RF	1683	591	1372	180	663	1593.8	44	1¼	965	-	-
	300	RF	1657	718	1372	270	666	1549.4	28	2¼	1185	-	-
1500 (60")	150	RF	1854	660	1524	279	740	1759	52	1¼	1055	-	-
	300	RF	1810	838	1524	-	-	1701.8	32	2¼	1330	-	-